

A View from the Bench – Trial Judges Panel

ChIPs Women in IP Global Summit
October 28, 2015



Hon. Linda Horner
Administrative Patent
Judge, USPTO

Hon. Lucy Koh
District Judge, USDC
Northern District of California

Hon. Sandra (Dee) Lord
Administrative Law
Judge, ITC

Hon. Sue L. Robinson
District Judge, USDC
District of Delaware

Moderator: Leslie Spencer, Ropes & Gray



Recent Supreme Court & Federal Circuit Cases

UNITED STATES
COURT OF APPEALS
FOR THE
FEDERAL CIRCUIT

Patentable Subject Matter

- *Alice Corp. Pty. Ltd. v. CLS Bank Int'l.*
134 S.Ct. 2347 (U.S. June 19, 2014)
- *Ariosa Diagnostics, Inc. v. Sequenom, Inc.*
726 F.3d 1296 (Fed. Cir. June 12, 2015)

Indefiniteness

- *Nautilus, Inc. v. Biosig Instruments, Inc.*
134 S.Ct. 2120 (U.S. June 2, 2014)

Claim Construction Standard of Review

- *Teva Pharm. USA, Inc. v. Sandoz, Inc.*
135 S.Ct. 831 (U.S. Jan. 20, 2015)

Divided Infringement

- *Limelight Networks, Inc. v. Akamai Techs., Inc.*
134 S.Ct. 2111 (U.S. June 2, 2014), *on remand*
797 F.3d 1020 (Fed. Cir. Aug. 13, 2015) (en banc)

Induced Infringement

- *Commil USA, LLC v. Cisco Sys., Inc.*
135 S.Ct. 1920 (U.S. May 26, 2015)

ITC Jurisdiction -- Induced Infringement

- *Suprema, Inc. v. Int'l Trade Comm.,*
796 F.3d 1338 (Fed. Cir. Aug. 10, 2015)

ITC Jurisdiction – Digital Importation

- *ClearCorrect Operating LLC, et al. v. Int'l Trade Comm.,* No. 2014-1527 (Fed. Cir.)

Post-Patent Expiration Royalties

- *Kimble v. Marvel Enterprises, Inc.*
135 S.Ct. 2401 (U.S. June 22, 2015)

Attorneys' Fees

- *Octane Fitness, LLC v. ICON Health & Fitness, Inc.*
134 S.Ct. 1749 (U.S. April 29, 2014)
- *Highmark Inc. v. Allcare Health Mgmt. Sys., Inc.* 134 S.Ct. 1744 (U.S. April 29, 2014)

Patent Exhaustion

- *Lexmark Int'l, Inc. v. Impression Prods., Inc.*
785 F.3d 565 (Fed. Cir. April 14, 2015)

Inter Partes Review

- *Cuozzo Speed Technologies, LLC v. Lee*
S. Ct., No. 15-446 (petition for writ of certiorari,
filed Oct. 6, 2015)

Alice Corp. Pty. Ltd. v. CLS Bank Int'l

S. Ct. June 19, 2014

- Applied *Mayo* two-step framework
 - Step 1: Determine whether the claims at issue are directed to patent-ineligible subject matter
 - Per *Alice*, “claims are drawn to the **abstract idea** of intermediated settlement.”
 - “Like the risk hedging in *Bilski*, the concept of intermediated settlement is ‘a **fundamental economic practice** long prevalent in our system of commerce.’”
 - Step 2: If so, “[w]hat else is there in the claims?”
 - Determine whether the additional elements “transform the nature of the claim” into a **patent-eligible application**
 - Identify “**inventive concept**” — element or combination of elements “sufficient to ensure that the patent in practice amounts to significantly more than a patent upon the [ineligible concept] itself.”

Ariosa Diagnostics, Inc. v. Sequenom, Inc.

Fed. Cir. June 12, 2015

- Applied *Mayo* two-step framework
 - Step 1: Are claims directed to naturally occurring matter? YES
 - “asserted claims of the ’540 patent are directed to a multistep method that starts with cffDNA taken from a sample of maternal plasma or serum—a naturally occurring non-cellular fetal DNA that circulates freely in the blood stream of a pregnant woman”
 - Claimed method included steps of taking fetal DNA from maternal plasma; amplifying and extracting that DNA; detecting paternally inherited fetal DNA; and diagnosing fetal characteristics
 - Step 2: Is there an inventive concept sufficient to “transform” the naturally occurring phenomenon into patent-eligible application? NO
 - “The method at issue here amounts to a general instruction to doctors to apply routine, conventional techniques when seeking to detect cffDNA. . . . method steps were well-understood, conventional and routine, . . . The only subject matter new and useful as of the date of the application was the discovery of the presence of cffDNA in maternal plasma or serum.”

Nautilus, Inc. v. Biosig Instruments, Inc.

S. Ct. June 2, 2014

- S. Ct. held “reasonable certainty” standard for indefiniteness
 - A patent is invalid for indefiniteness if its claims, read in light of the specification delineating the patent, and the prosecution history, fail to inform, with reasonable certainty those skilled in the art about the scope of the invention.
- Federal Circuit, on remand :
 - The term “spaced relationship” does not run afoul of “the innovation-discouraging ‘zone of uncertainty’ against which [the Supreme Court] has warned,” and to the contrary, informs a skilled artisan with reasonable certainty of the scope of the claim.

Electrodes such as 9 and 11 are claimed to be “mounted...in spaced relationship with each other”

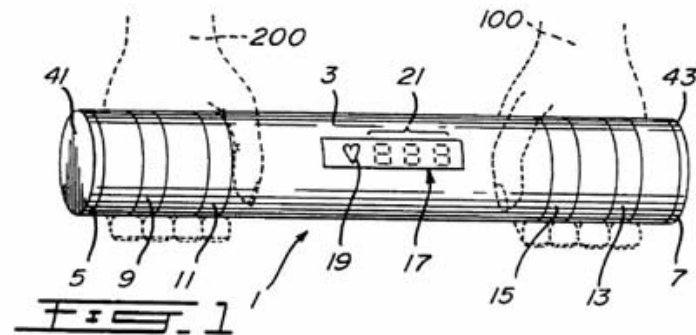

Teva Pharm. USA, Inc. v. Sandoz, Inc.

S. Ct. Jan. 20, 2015

- Claim construction is a matter of law, but may involve “factual underpinnings” and resolution of underlying factual disputes
- Court of Appeals must apply “clear error” standard when reviewing district court’s factual findings
- Standard of review differs for intrinsic and extrinsic evidence
 - When district courts review only intrinsic evidence, their determination will be one of law, subject to de novo review
 - When district courts consult extrinsic evidence, determinations about that evidence will be an issue of fact

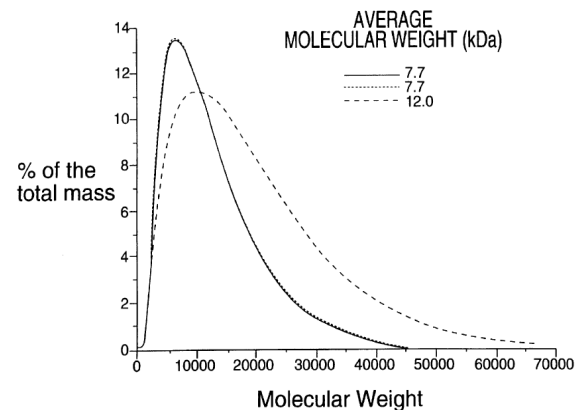

U.S. Patent No. 5,981,589, Fig. 1

Limelight Networks v. Akamai Techs.

S. Ct. June 2, 2014

- Supreme Court held:
 - There can be no liability for induced infringement under 35 U.S.C. §271(b) unless one party can be held liable for direct infringement under §271(a).
- Federal Circuit, on remand (*en banc*), Aug. 13, 2015:
 - “[L]iability under § 271(a) can also be found when an alleged infringer conditions participation in an activity or receipt of a benefit upon performance of a step or steps of a patented method and establishes the manner or timing of that performance. ”
 - “Section 271(a) is not limited solely to principal-agent relationships, contractual arrangements, and joint enterprise, as the vacated panel decision held. Rather, to determine direct infringement, we consider whether all method steps can be attributed to a single entity.”

Commil USA, LLC v. Cisco Sys., Inc.

S. Ct. May 26, 2015

- “A defendant’s belief regarding patent validity is not a defense to an induced infringement claim.”
- Infringement and invalidity are “separate issues under the Act,” and belief regarding invalidity cannot negate scienter for inducement.

Suprema, Inc. v. Int'l Trade Comm

Fed. Cir. Aug. 10, 2015

- Applied *Chevron* two step framework
 - Step 1: Is term “articles . . . that infringe” in Section 337 ambiguous when viewed in the context of the patent laws of the United States?
 - **Yes**: Under the patent laws, “articles” do not infringe, people do.
 - Step 2: Is ITC’s construction of the term “articles . . . that infringe” is reasonable in light of the text, purpose, and history of Section 337?
 - **Yes**: Interpretation has been consistent for 35 years, and within ITC’s authority per 1988 Amendments by Congress
- ITC’s interpretation of the term “articles . . . that infringe” to cover goods used by an importer to directly infringe post-importation as a result of the seller’s inducement **was reasonable** in the context of the statutory authority endowed to the ITC by Congress.



ClearCorrect Operating LLC, et al. v. Int'l Trade Comm

- Fed. Cir. Appeal. No. 2014-1527
 - Appeal of ITC final determination, Investigation No. 337-TA-562, *In re Certain Digital Models*
- Fed. Cir. oral argument held Aug. 11, 2015
- ITC interpreted “articles” to include digital data sets created outside of U.S. and uploaded in U.S.
 - ClearCorrect sends scans of teeth outside U.S. to technicians who design braces and store designs in digital data sets on a server
 - ClearCorrect uses digital data sets in Texas to print 3-D physical models of braces
- On appeal, ITC argues *Chevron* deference applies
- At oral argument, Fed. Cir. requested additional briefing on impact of *Suprema*



Kimble v. Marvel Enterprises, Inc.

S. Ct. June 22, 2015

- Court declined to overrule *Brulotte v. Thys Co.*, 379 U.S. 29 (1964)
- *Brulotte* held that a license agreement requiring royalty payments for use of a patented invention after expiration of the patent term is unlawful *per se*.
- Justice Kagan offered drafting tips for royalty payments received after patent expiration
 - Deferred payments for pre-expiration use of patent in post-expiration period
 - Royalties may run until latest-running patent covered in agreement expires
 - Post-expiration royalties allowable as long as tied to a non-patent rights
 - Joint ventures and other creative licensing arrangements permissible



Octane Fitness v. ICON Health & Fitness

S. Ct. April 29, 2014

- Standard for “exceptional case” when awarding attorney fees under 35 U.S. C. §285
- A case is exceptional when it “stands out from others with respect to the substantive strength of a party’s litigating positions ... or the unreasonable manner in which the case was litigated”
- The “exceptional case” determination is made on “a case-by-case exercise of [district court judge’s] discretion, considering the totality of the circumstances”



Highmark v. Allcare Health Mgmt. Sys.

S. Ct. April 29, 2014

- Standard of review: Attorneys' fees
 - Standard of review for determination of whether a case is “objectively baseless” as part of determination to award attorney fees
 - Held that Court of Appeals should apply abuse of discretion standard
 - District court is entitled to deference



Lexmark Int'l v. Impression Prods.

Fed. Cir. April 14, 2015

- Patent Exhaustion

- Federal Circuit sua sponte ordered rehearing en banc
- Hearing en banc, held October 2, 2015
- En banc order requested briefing on two issues:
 - a) Should this court overrule *Jazz Photo Corp. v. International Trade Commission*, 264 F.3d 1094 (Fed. Cir. 2001), to the extent it ruled that a sale of a patented item outside the United States never gives rise to United States patent exhaustion.
 - b) In light of *Quanta Computer, Inc. v. LG Electronics, Inc.*, 553 U.S. 617 (2008), should this court overrule *Mallinckrodt, Inc. v. Medipart, Inc.*, 976 F.2d 700 (Fed. Cir. 1992), to the extent it ruled that a sale of a patented article, when the sale is made under a restriction that is otherwise lawful and within the scope of the patent grant, does not give rise to patent exhaustion?

Cuozzo Speed Technologies, LLC v. Michelle K. Lee

- BRI and reviewability of IPR decisions
 - Petition for writ of certiorari, filed Oct. 6, 2015
 - Two questions presented:
 1. Whether Fed. Circuit erred in holding that, in IPR proceedings, the Board may construe claims in an issued patent according to their broadest reasonable interpretation rather than their plain and ordinary meaning
 2. Whether Fed. Circuit erred in holding that, even if the Board exceeds its statutory authority in instituting an IPR proceeding, the Board's decision whether to institute an IPR proceeding is judicially unreviewable.

